

# STAINLESS STEEL

**DAW**  
SERIES

PIC-A-WATT FAMILY - FAN FORCED  
CORROSION RESISTANT



## FEATURES:

- 304 Stainless Steel
  - Pic-A-Watt® Element
  - C-Frame Motor
  - Squirrel Cage Blower
  - Quiet Running
- Flange Mount Wall Can
  - Multiple Wattage Selection
  - 20 Gauge Clear Powder Coated Grill with die formed square corners.
  - Green Pilot Light indicates when heat is on.
  - Bimetallic limit turns the element off when an over temperature condition occurs and automatically resets when the normal temperature returns.
  - Manual Reset Limit turns heater off and is reset by thermostat
  - 1-Pole or 2-Pole unit mount thermostat 45°-80°F
  - Optional Surface Wall Box

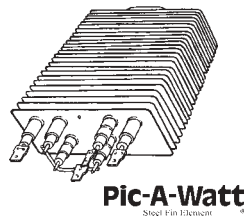

A heavy duty industrial switch mounted on the grill allows easy choice of 7 different power settings with ease. Use where higher wattage is not required during unoccupied periods and freeze protection may be achieved with energy savings. Quiet operating tangential blower and commercial grade element make the Dial-A-Watt the heater of choice for people on the move. Typical installations are boats and pleasure crafts where

corrosion resistant construction is required. By providing air movement and dry heat, must and mold odors are reduced.

During use, the heater load (Amperage) can be adjusted to the shore power cord that is feeding the vessel. This prevents damage to plugs and receptacles due to over loading. During unoccupied periods, wattage can be adjusted to the correct level for freeze protection.

## ENGINEERING SPECIFICATIONS:

Contractor shall supply and install, DAW Stainless Steel Series wall-mounted forced-air electric heaters, manufactured by King Electrical Mfg. Company, of the wattage and voltage as indicated on the plans.

**Ratings:** Heaters shall be available in wattages of 250 to 2,250 at 120, 208, or 240 volts.

**Blower and Motor:** A tangential cylindrical blower, delivering 70 CFM, shall be driven by a shaded pole, permanently lubricated, C-frame type motor with impedance protection and sealed bearings. Motors shall be the same voltage as the heater.

**Elements:** Elements assemblies shall be non-glowing design. Element assemblies shall consist of steel sheathed heating tubes in a furnace brazed, plate finned, block design. Each sheathed tube shall contain coiled a Ni-Chrome wire, embedded in an insulator of magnesium oxide.

**Thermal Overload:** Heaters shall be equipped with thermal overload protection, which disconnects elements in the event normal operating temperatures are exceeded. The thermal overload protection device shall automatically reset when normal operating temperatures are reached or manually reset by the thermostat.

**Wall Can:** The wall can shall be stainless steel and shall contain a minimum of three (3) knockouts through which power leads are brought. The wall can shall have a depth gauge or flange mount, and a factory installed copper grounding wire. Minimum Clearance to Floors and Sidewalls. Zero clearance to combustibles.

**Grill:** 304 Brushed Stainless Steel, Clear Powder Coating  
**Approval:** Heaters shall be listed and approved by Underwriters' Laboratories or equal.

**Selector Switch:** Shall provide 7 wattage settings adjustable from switch on front of heater.

**Indicator:** Light designates heater is operating.

**MODEL CODE:**

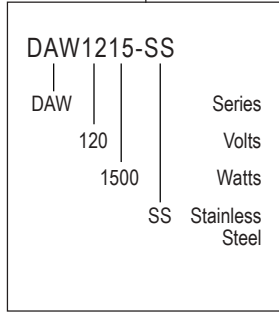

Standard Color: Bright White

**SELECTION:**

WATTAGE	120V		208V		240V		WEIGHT (lbs)
	MODEL	UPC #093319 PART NO.	MODEL	UPC #093319 PART NO.	MODEL	UPC #093319 PART NO.	
250-500-750-1000-1250-1500	DAW1215-SS	19251					10
500-750-1000-1250-1500-1750-2250			DAW2022-SS	19208	DAW2422-SS	19252	
1000-2000							
OPTIONS							
ADD PREFIX:	DESCRIPTION						
D-	For Decade Motor - Not Available with Inbuilt T-Stats due to Motor Size						11.5



Dial-A-Watt Heater Selector Switch and Green Indicator Light

**ACCESSORIES:**

MODEL	DESCRIPTION	UPC #093319 PART NO.	WEIGHT
PAWS-SS	Pic-A-Watt Surface Can - White	16317	4
PT-1-SS	Stat Kit SPST	16309	.5
PT-2-SS	Stat Kit DPST	16311	.5

**Typical Shore Power Loads:**

ITEM	AMPS
Battery Charger	7
Inverter	10/25
Hot Water Tank	12.5
Hair Dryer	14
Microwave	8
Portable Heater	12.5
Stove/Range Top	20
Coffee/Esspresso	6/8
Toaster	11.6
Hot Air Popper	10
Dial-A-Watt	2 to 12.5

**DIMENSIONS**

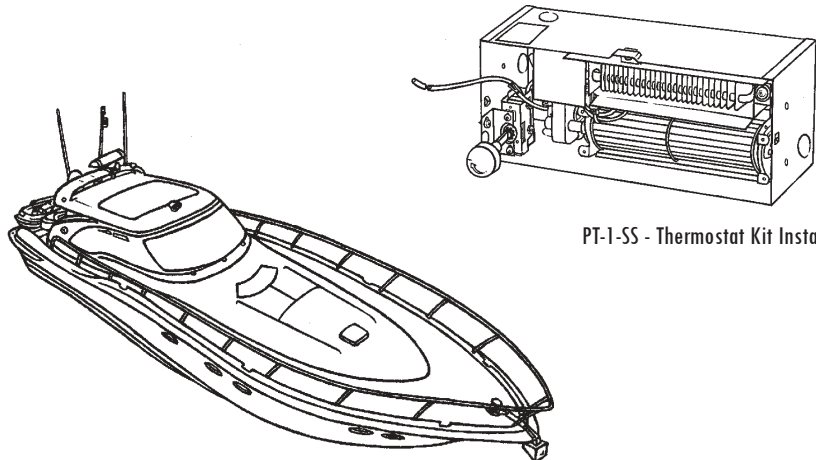
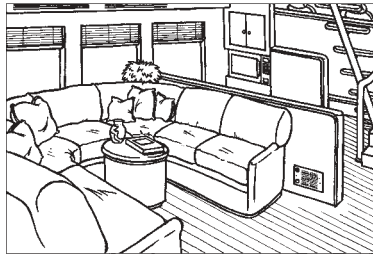
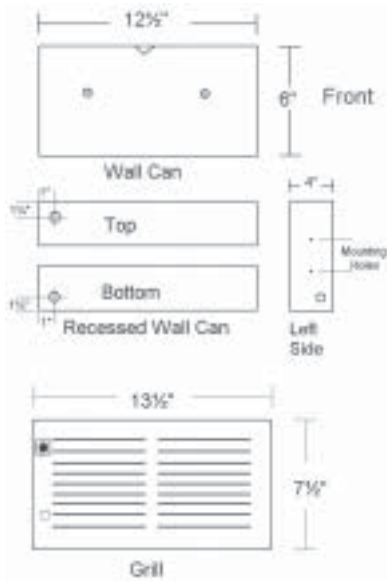

PT-1-SS - Thermostat Kit Installed