

FLOOR HEATING

KTM
SERIES

120, 208/240 Volt • Single Phase

Bathroom, kitchen and hallway



FEATURES

- Voltage** - 120V, 240V/208V, 1-Phase.
- Construction** - Heating cable made of a twin conductor for better mechanical resistance and negligible magnetic field in a protective PVC sheath fastened to an adhesive fiberglass mat with a cold lead of 13' 6".
- Watt Density** - 12W/sq. ft.
- Dimension** - Standard width is 16" and the mat becomes longer when the room size increases. 32" wide mats are available for applications over 70 square feet.
- Cold lead length** - 13' 6".
- Control** - Non-programmable electronic thermostat with backlight and GFCI (120V or 240V/208V) sold separately.
- Programmable electronic thermostat with backlight and GFCI (120V or 240V/208V) sold separately.
- Installation** - **Never cut or shorten the heating cable.**
- For indoor residential applications only.
- On concrete slab or plywood subfloor.
- Warranty** - 25-year warranty on heating wire.
- 1-year warranty on thermostat.

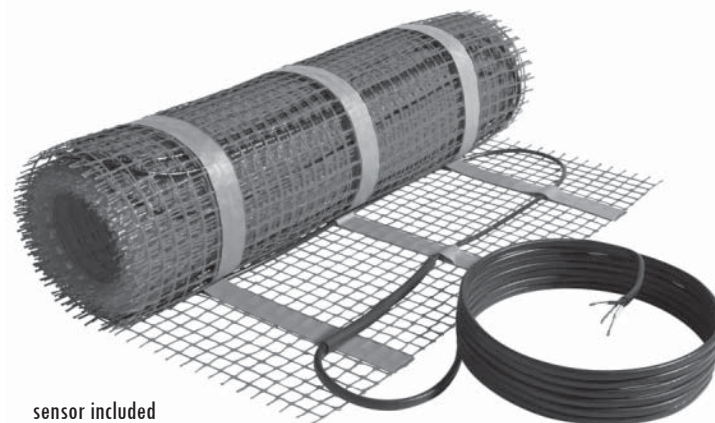

The KING floor heating system provides comfort and well-being through radiant heat. By heating the floor itself instead of the surrounding air, the system provides indirect heat that radiates from the floor up and is absorbed by surrounding objects, warming the entire room. As an integrated heating system, it produces enveloping, invisible heat that is also clean, cost-effective, uniform, and constant.

Perfectly suited for kitchens, living rooms, showers (even the ceramic floor IN a shower!), hallways, and staircases. Can be used as a primary or supplemental heat source.

ENGINEERING SPECIFICATIONS:

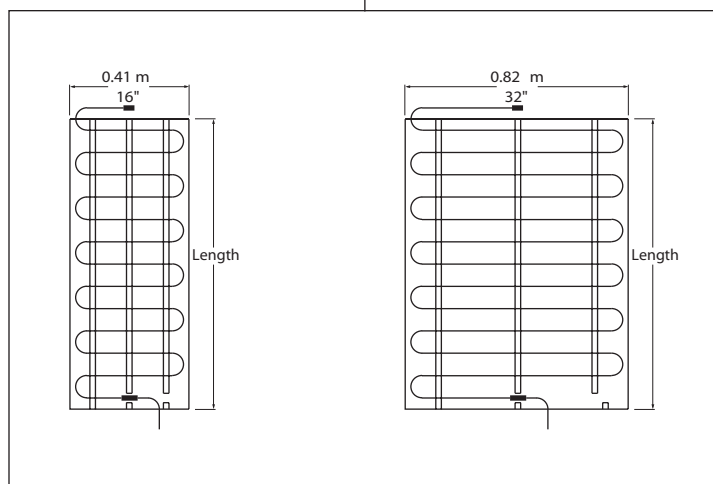

EFP230-GFCI



SELECTION:

WATTAGE	120V		240V/208V		WIDTH (inches)	LENGTH (feet)	SURFACE AREA (sq. ft.)	List Price
	UPC# 093319 Part#	MODEL	UPC# 093319 Part#	MODEL				
85	30001	KTM12008			16	6	8	\$264.71
120	30003	KTM12012			16	7' 9"	10	\$264.71
150	30005	KTM12015			16	9' 9"	13	\$315.13
170	30009	KTM12017	30007	KTM24017	16	11' 3"	15	\$357.14
240	30013	KTM12024	30011	KTM24024	16	15' 3"	20	\$420.17
300	30017	KTM12030	30015	KTM24030	16	18' 9"	25	\$462.18
360	30021	KTM12036	30019	KTM24036	16	22' 6"	30	\$525.21
420	30025	KTM12042	30023	KTM24042	16	26' 6"	35	\$609.24
475	30027	KTM12047	30029	KTM24047	16	30'	40	\$672.27
600	30033	KTM12060	30031	KTM24060	16	37' 6"	50	\$798.32
720	30037	KTM12072	30025	KTM24072	16	45'	60	\$840.34
840	30043	KTM12084	30039	KTM24084	16	52' 9"	70	\$966.39
	30045	KTM12084-32	30041	KTM24084-32	32	26' 4"	70	\$966.39
960	30051	KTM12096	30047	KTM24096	16	60'	80	\$1092.44
	30053	KTM12096-32	30049	KTM24096-32	32	30'	80	\$1092.44
1080			30055	KTM24108	16	67' 9"	90	\$1218.49
			30057	KTM24108-32	32	33' 10"	90	\$1218.49
1200			30059	KTM24120	16	75' 3"	100	\$1344.54
			30061	KTM24120-32	32	37' 9"	100	\$1344.54
1440			30063	KTM24144	16	90'	120	\$1470.59
			30065	KTM24144-32	32	45'	120	\$1470.59
1600			30067	KTM24160	16	105'	140	\$1974.79
			30069	KTM24160-32	32	52' 6"	140	\$1974.79
1920			30071	KTM24192	16	120'	160	\$2,100.84
			30073	KTM24192-32	32	60'	160	\$2,100.84

ACCESSORIES			
MODEL	UPC# 093319 Part#	DESCRIPTION	List Price
LTC6832	30075	Floor Mat Spray Adhesive	\$34.31
KTM-KIT	30077	Floor Mat Repair Kit	\$49.02
KTM-CC	30079	Floor Mat Cable Monitor	\$63.73

FLOOR HEATING THERMOSTATS

FEATURES

- Type** - Floor heating thermostat with LED backlight.
- Color** - White.
- Voltage** - 120V or 240V, battery-free setpoint temperature recorded permanently.
- Control** - Setpoint temperature precision within $\pm 1^\circ\text{F}$.
- Temperature monitoring takes place 240 times per hour.
- T° range** - 40°F to 104°F.
- Vacation setpoint: 50°F.
- Display** - Digital display of floor temperature ($^\circ\text{C}$ or $^\circ\text{F}$) heating level indicator. Ground fault circuit interrupter included for safety with GFCI test light.
- On / standby switch to enable thermostat shutdown.
- Installation** - 4-wire thermostat.
- Warranty** - 1-year warranty against defects.



OTH700
Non-Programmable



TH115
Programmable

The OTH700 and TH115 Series electronic thermostats are specifically designed to regulate King Mat floor heating systems. The TH115 is programmable.

They feature a sensor to regulate and maintain floor or room temperature to within $\pm 1^\circ\text{F}$ of the setpoint. Designed for maximum safety, they include a ground-fault circuit interrupter (GFCI), which King strongly recommends for all rooms with heated floors and is required in wet locations.

To facilitate temperature control, the digital display indicates floor temperature at all times. A single touch activates the backlight display and indicates setpoint.

Floor sensor included. 1 year warranty.

SELECTION:

MODEL	DESCRIPTION	mA	VOLTS	PROTECTION
OTH702-GA	Non-Programmable Electronic Floor Temperature Control	5	120	GFCI
OTH700-GA		5	240 / 208	
TH115-F-120-GA	Programmable Electronic Floor Temperature Control	5	120	GFCI
TH115-F-240-GA		5	240 / 208	

- 1) GFCI: Ground fault circuit interrupter
- 2) 15' floor sensor included
- 3) Approved for wet locations